

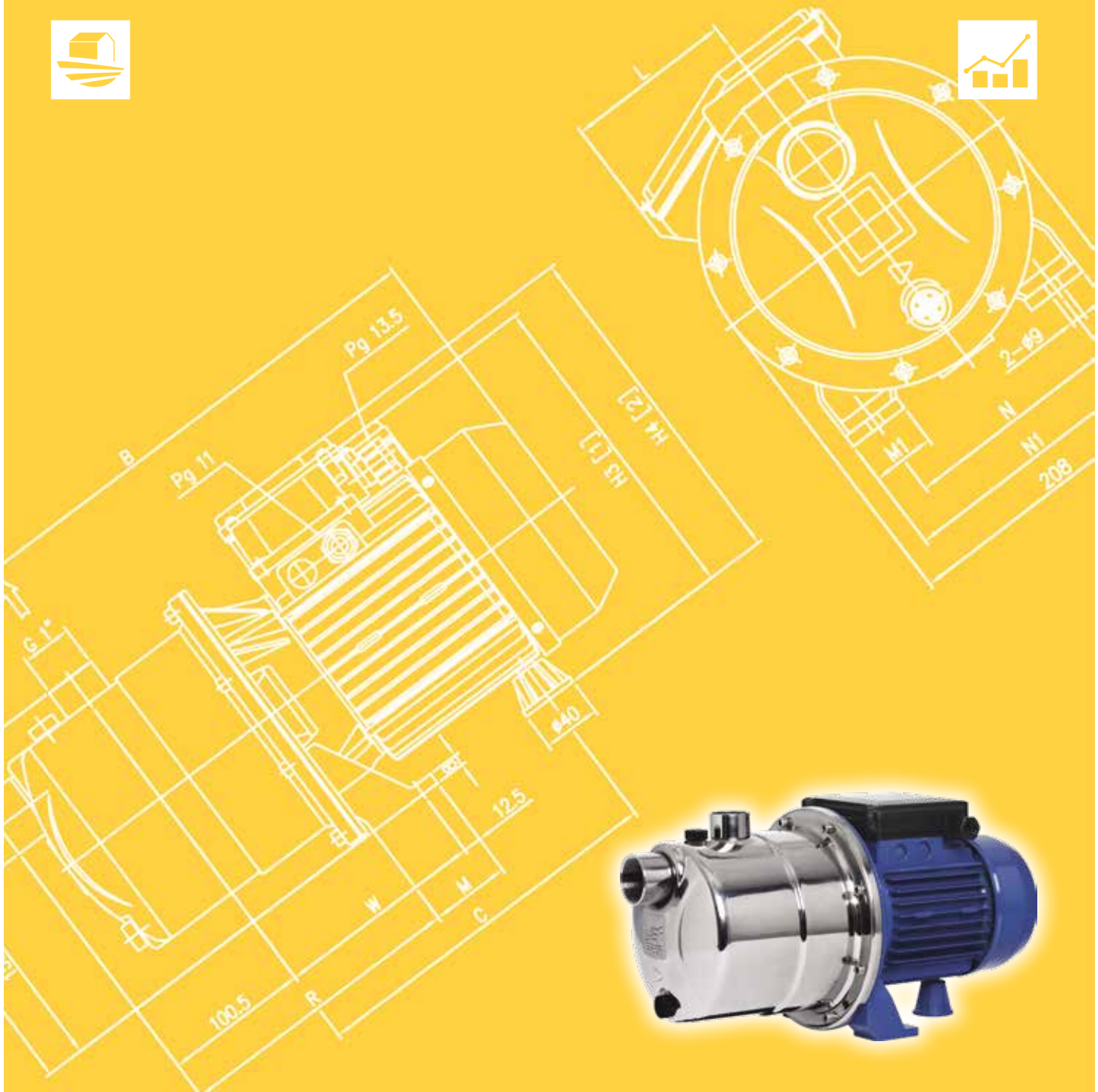

Japanese Technology since 1912

JEX

Data Book 60Hz



	Page
- SPECIFICATIONS	200
PERFORMANCE RANGE and SELECTION CHART	201
TYPE KEY and CURVES SPECIFICATIONS	202
PERFORMANCE CURVES JEX 806	203
PERFORMANCE CURVES JEX 1006	203
PERFORMANCE CURVES JEX 1506	203
- CONSTRUCTIONS	300
SECTIONAL VIEW	300
MECHANICAL SEAL	301
BEARINGS	301
- DIMENSIONS and WEIGHT	400
PUMP	400
PACKING	401
- TECHNICAL DATA	500
MOTOR DATA	500
- INSTALLATION	600

PERFORMANCE RANGE and SELECTION CHART

60Hz

Rev. D

PUMP		
Liquid Handled	Type of liquid	Clean water
	Temperature [°C]	min. +5 max. +45
Maximum working pressure	[MPa]	0.8
Maximum suction depth	[m]	8
Construction	Impeller	Closed centrifugal type
	Shaft seal type	Mechanical seal
	Bearing	Sealed ball bearing
Pipe Connection	Suction [inch]	G 1¼ UNI ISO 228
	Discharge [inch]	G 1 UNI ISO 228
Material	Casing	AISI 304
	Impeller	AISI 304
	Shaft seal	Ceramic/Carbon/NBR
	Casing cover	AISI 304
	Shaft	AISI 303 (Wet extension)
	Bracket	Aluminium
	Ejector	PPE+PS glass fibre reinforced
Diffuser	PPE+PS glass fibre reinforced	
Applicable standard of test		ISO 9906:2012 - Grade 3B

MOTOR		
Type	Electric - TEFC	
	Single Phase	Three Phase
Efficiency Level (Rif.1781/2019)	-	IE3
No. of Poles	2	
Rotation speed [min ⁻¹]	≈ 3450	
Insulation Class	F	
Protection degree (CEI EN 60034-5)	IP 54 IP 55 (on request)	
Power rating [kW]	0.6 ÷ 1.1	
[HP]	0.8 ÷ 1.5	
Frequency [Hz]	60	
Voltage [V]	110-115V ±6% 220-230V ±6%	220/380 -6% +10% (0.6 kW) 220/380 ±10% (0.75 kW - 1.1 kW) 220/380-460 ±10% (IE3* 0.75 - 1.1 kW)
Capacitor	Built in	-
Over load protection	Built in	Provided by the user
Casing material	Aluminium	
Base material/motor support	Aluminium	
Dimensions of cable entry	PG11 - M16x1.5 - M20x1.5 (see DIMENSIONS TABLE page 400)	

PERFORMANCE RANGE

PERFORMANCE RANGE and SELECTION CHART

60Hz

Rev. D

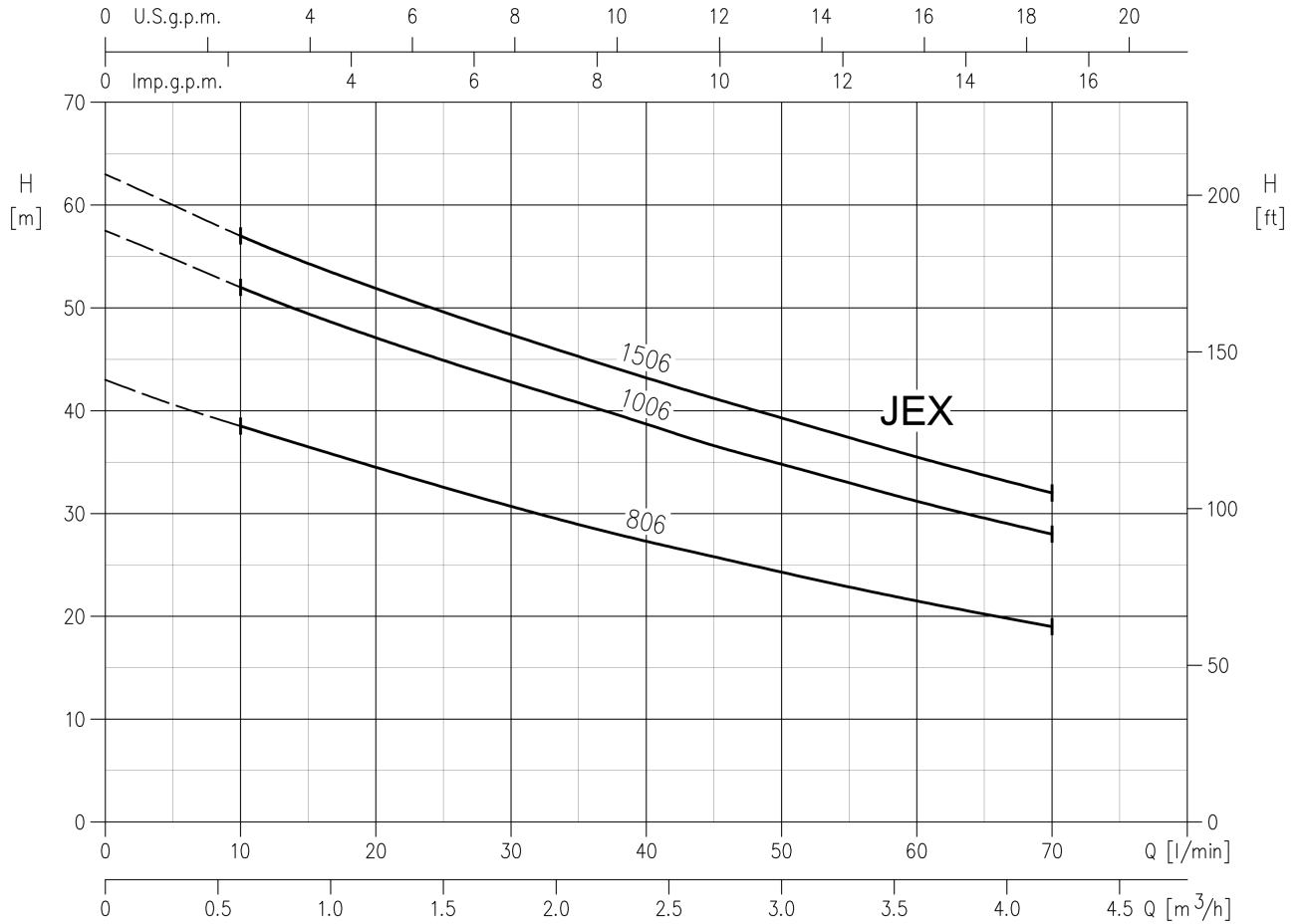

SELECTION CHART

Pump type		Power		Q=Capacity											
Single-phase	Three-phase	[kW]	[HP]	l/min.	0	5	10	20	30	40	45	50	60	70	
				m³/h	0	0.3	0.6	1.2	1.8	2.4	2.7	3.0	3.6	4.2	
H=Total manometric head in meters															
JEXM 806	JEX 806	0.6	0.8	43	-	38.5	35	30.7	27.3	25.8	24.3	21.5	19		
JEXM 1006	JEX 1006	0.75	1.0	57.5	-	52	47	43	38.7	36.6	34.8	31.2	28		
JEXM 1506	JEX 1506	1.1	1.5	63	-	57	52	47.5	43.2	41.2	39.3	35.5	32		

TYPE KEY

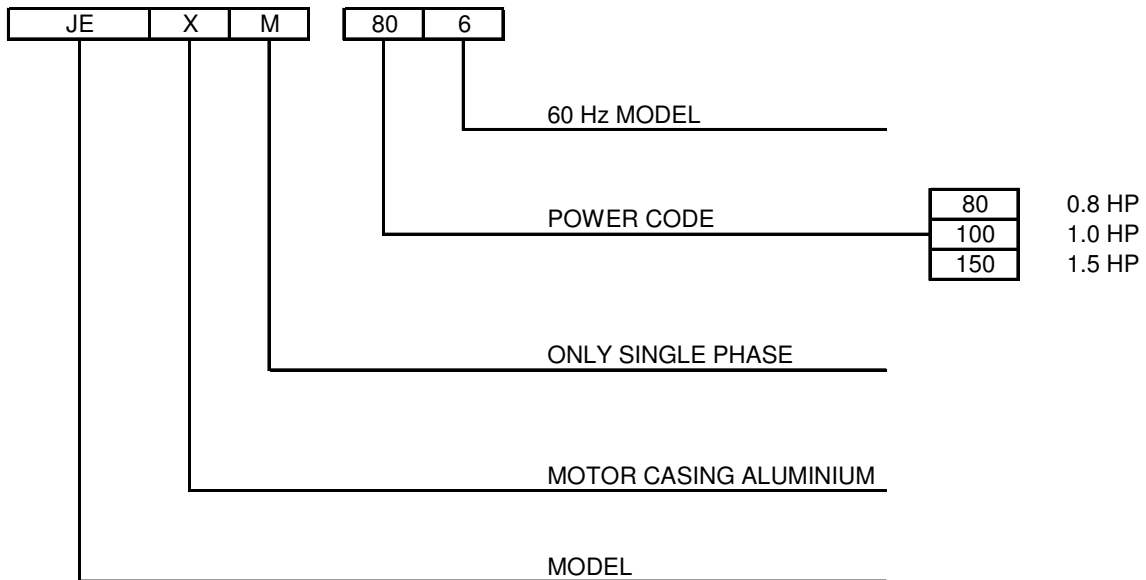

CURVES SPECIFICATIONS

The specifications below qualify the curves shown on the following pages.

Tolerances according to ISO 9906:2012 - Grade 3B

The curves refer to effective speed of asynchronous motors at 60 Hz, 2 poles.

Measurements were carried out with clean water at 20°C of temperature and with a kinematic viscosity of $\nu = 1 \text{ mm}^2/\text{s}$ (1 cSt)

The continuous curves indicate the recommended working range. The dotted curve is only a guide.

In order to avoid the risk of over-heating, the pumps should not be used at a flow rate below 10% of best efficiency point.

Symbols explanation:

- Q = volume flow rate
- H = total head

JEX 806 - Impeller diameter = 115 mm
JEX 1006 - Impeller diameter = 132 mm
JEX 1506 - Impeller diameter = 132 mm

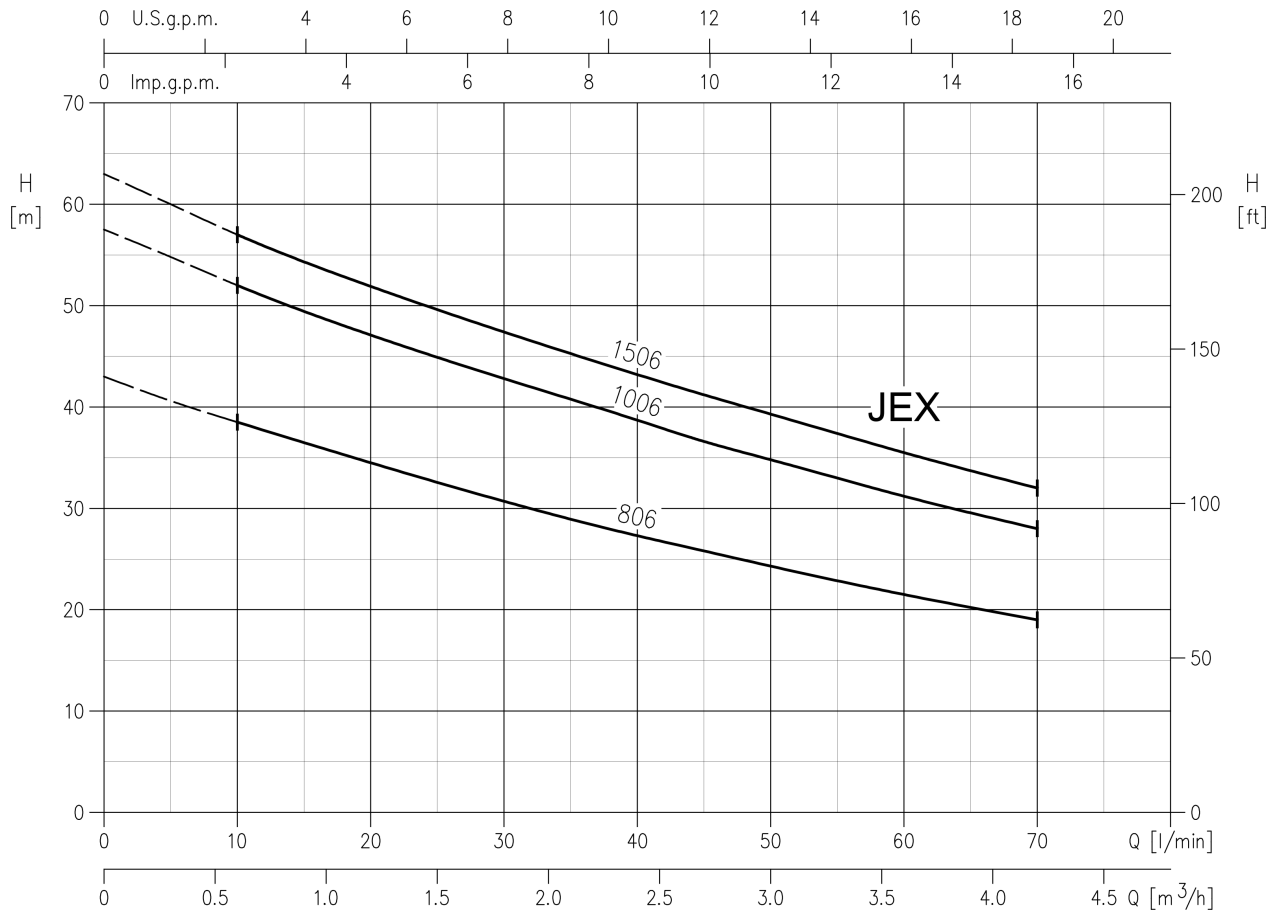

Rotation speed $\approx 3450 \text{ min}^{-1}$
 Test standard: ISO 9906:2012 - Grade 3B

SECTIONAL VIEW

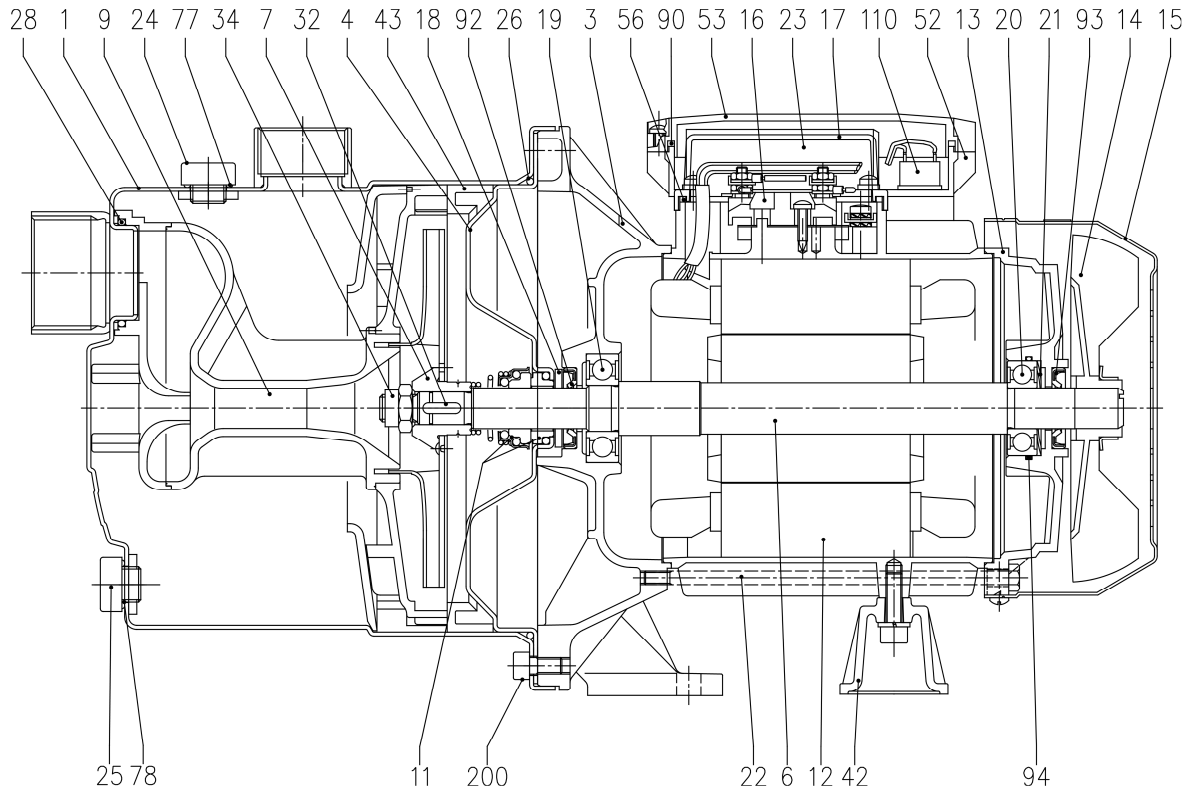

N°	PART NAME	MATERIAL	Q.TY	N°	PART NAME	MATERIAL	Q.TY
1	Casing	AISI 304	1	24	Priming plug	PA	1
3	Motor bracket	Aluminium	1	25	Drain plug	PA	1
4	Casing cover	AISI 304	1	26	O-ring	NBR	1
6	Shaft with rotor	AISI 303 (Wet extension)	1	28	O-ring	NBR	1
7	Impeller	AISI 304	1	32	Key	AISI 304	1
9	Diffuser Venturi tube	PPE+PS glass fibre reinforced	1	34	Impeller nut	AISI 304	1
11	Mechanical seal [4]	Carbon/Ceramic/NBR	1	42	Motor support	Aluminium	1
12	Motor frame with stator	-	1	43	Space diffuser	PPE+PS glass fibre reinforced	1
13	Motor cover	Aluminium	1	52	Capacitor box [1]	ABS class V-0	1
14	Fan	PA	1	53	Capacitor box cover [1]	ABS class V-0	1
15	Fan cover	Fe P04 Zincate	1	56	Box gasket	NBR	1
16	Terminal board	-	1	77	O-ring	NBR	1
17	Terminal box cover [2]	Aluminium	1	78	O-ring	NBR	1
18	Splash ring	NBR	1	90	Terminal box cover gasket [1]	NBR	1
19	Pump side ball bearing	-	1	92	Lip seal [3]	-	1
20	Fan side ball bearing	-	1	93	Lip seal [3]	-	1
21	Adjusting ring	Steel C70	1	94	O-ring [5]	NBR	1
22	Tie rod	Fe 420 Zincate	4	110	Protector [1]	-	1
23	Capacitor [1]	-	1	200	Screw	Stainless steel A2 UNI7323	8

- [1] Only for Single phase
- [2] Only for Three phase
- [3] Only for IP55
- [4] See **MECHANICAL SEAL** page 301
- [5] Only for JEX 1506 (three phase)

MECHANICAL SEAL

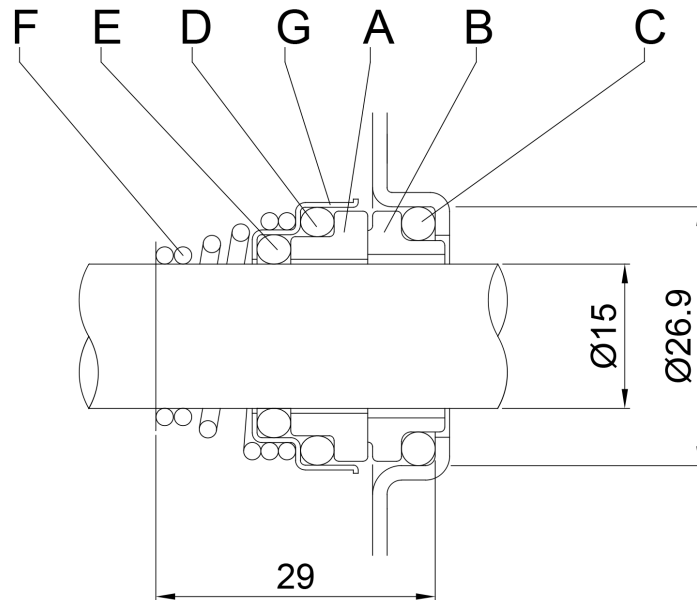

REF	PART NAME	MATERIAL
		Standard version
A	Rotary seal ring	ceramic
B	Stationary seal ring	carbon graphite
C	O Ring	NBR
D	O Ring	NBR
E	O Ring	NBR
F	Self driving spring	AISI 316
G	Frame	AISI 304

BEARINGS

Pump type		Ball Bearing	
Single Phase	Three Phase	Pump side	Fan side
JEXM 806	JEX 806	6203 2DW C3	6202 2DW C3
JEXM 1006	JEX 1006	6203-ZZ C3	6202-ZZ C3
JEXM 1506	JEX 1506	6203-ZZ C3	6202-ZZ C3

PACKING

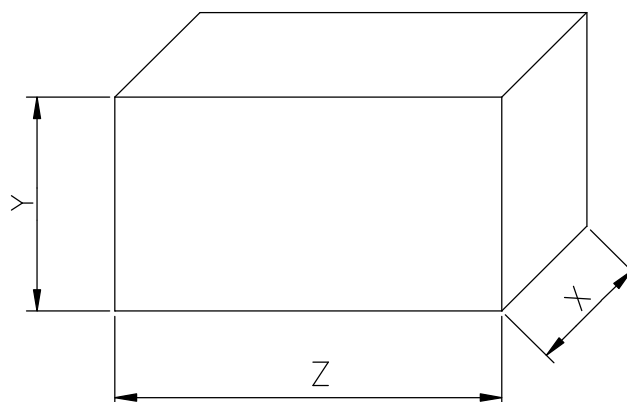

Pump type		X	Y	Z	Weight [kgf]	
Single Phase	Three Phase				[1~]	[3~]
JEXM 806	JEX 806	215	462	462	11	12
JEXM 1006	JEX 1006	215	462	462	12	12
JEXM 1506	JEX 1506	215	462	462	15	17

[1~] Single phase

[3~] Three phase

MOTOR DATA

Pump type		Power		Efficiency		Capacitor				Efficiency (% load)			Efficiency (% load)		Input		Full load current					Locked rotor current					
Single Phase	Three Phase	[kW]	[HP]	Single Phase	Three Phase	110-115 V		220-230 V		Three phase (380 V)			Three phase (460 V)			Single Phase	Three Phase	[A]					[A]				
						[μF]	[V]	[μF]	[V]	50%	75%	100%	50%	75%	100%	Phase	Phase	110-115 V	220-230 V	220 V	380 V	460 V	110-115 V	220-230 V	220 V	380 V	460 V
JEXM 806	JEX 806	0,6	0,8	-	IE3	60	250	14	450	82,3	83,5	83,2	80,5	83,1	84,6	1,0	0,90	9,2	4,9	2,8	1,6	0,5	48,8	23,2	17,9	10,3	12,5
JEXM 1006	JEX 1006	0,75	1,0	-	IE3	70	250	20	450	80,7	81,9	81,3	78,4	81,6	83,1	1,5	0,90	13,3	7,2	2,8	1,6	1,5	68,0	34	16,9	9,7	11,8
JEXM 1506	JEX 1506	1,1	1,5	-	IE3	-	-	25	450	84,8	84,5	82,7	82,0	84,4	84,5	1,7	1,30	-	8,1	4,0	2,3	2,2	-	37	24,6	14,2	17,2

If you use this pump on suction condition , it tends to breath the air from outside because the pressure in pump becomes vaccum condition when it stopped. So water in the pump sometimes fall down to breath the air from pipe connection. If it is used to operate continuously under this condition, this is the cause of breakdown to overheat inside the pump.



So please install foot valve or check valve at suction pipe in order to prevent the pump from such a condition. And moreover will you please support the suction pipe and the delivery one to prevent the pump from leaning the weight of pipe.

