



Japanese Technology since 1912

AGA

Data Book 60Hz



	Page
- SPECIFICATIONS ^①	200
PERFORMANCE RANGE and SELECTION CHART	201
TYPE KEY and CURVES SPECIFICATIONS	202
PERFORMANCE CURVES	203
- CONSTRUCTIONS	300
SECTIONAL VIEW	300
MECHANICAL SEAL	301
BEARINGS	301
- DIMENSIONS and WEIGHT	400
PUMP	400
PACKING	401
- TECHNICAL DATA	500
MOTOR DATA	500

① click INDEX to jump CORRESPONDING SECTION

② click  to go back to INDEX

SPECIFICATIONS

60Hz

Rev. E

PUMP		
Liquid Handled	Type of liquid	Clean water
	Temperature [°C]	min. +5 max. +45
Maximum working pressure	[MPa]	0.6 (AGA 076-106) 1.0 (AGA 156-206-306)
Maximum suction depth	[m]	8
Construction	Impeller	Closed centrifugal type
	Shaft seal type	Mechanical seal
	Bearing	Sealed ball bearing
Pipe Connection	Suction	G 1 (AGA 076-106) UNI ISO 228 G 1½ (AGA 156-206-306) UNI ISO 228
	Discharge	G 1 UNI ISO 228
	Casing	Cast iron
Material	Impeller	PPE+PS glass fibre reinforced (AGA 076-106) Brass (AGA 156-206-306)
	Shaft seal	Ceramic/Carbon/NBR
	Casing cover	AISI 304 (AGA 076-106) Cast iron built-in the motor bracket (AGA 156-206-306)
	Shaft	AISI 303 (wet extension)
	Bracket	Aluminium (AGA 076-106) Cast iron (AGA 156-206-306)
	Ejector	PPE+PS glass fibre reinforced
	Diffuser	PPE+PS glass fibre reinforced
	Applicable standard of test	ISO 9906:2012 - Grade 3B

MOTOR		
Type	Electric - TEFC	
	Single Phase	Three Phase
Efficiency Level	-	- 0.55 kW - from 0.75 kW up to 2.2 kW IE3* from 0.75 kW up to 2.2 kW
No. of Poles	2	
Rotation speed [min ⁻¹]	≈3450	
Insulation Class	F	
Protection degree (CEI EN 60034-5)	IP 44	
Power rating [kW]	0.44÷1.5	0.44÷2.2
[HP]	0.6÷2	0.6÷3
Frequency [Hz]	60	
Voltage [V]	110-115 ±6% 220-230 ±6%	220/380 -6% +10% (0.55 kW) 220/380 ±10% (from 0.75 kW up to 2.2 kW) 220/380-460 ±10% (IE3* 0.75 kW up to 2.2 kW)
Capacitor	Built in	-
Over load protection	Built in	Provided by the user
Casing material	Aluminium	
Base material / Motor support	Plastic foot / Cast iron	
Dimensions of cable entry	PG11 - PG13.5 - M16x1.5 - M20x1.5 (see page 400)	

* only for 460

PERFORMANCE RANGE and SELECTION CHART

60Hz

Rev. E

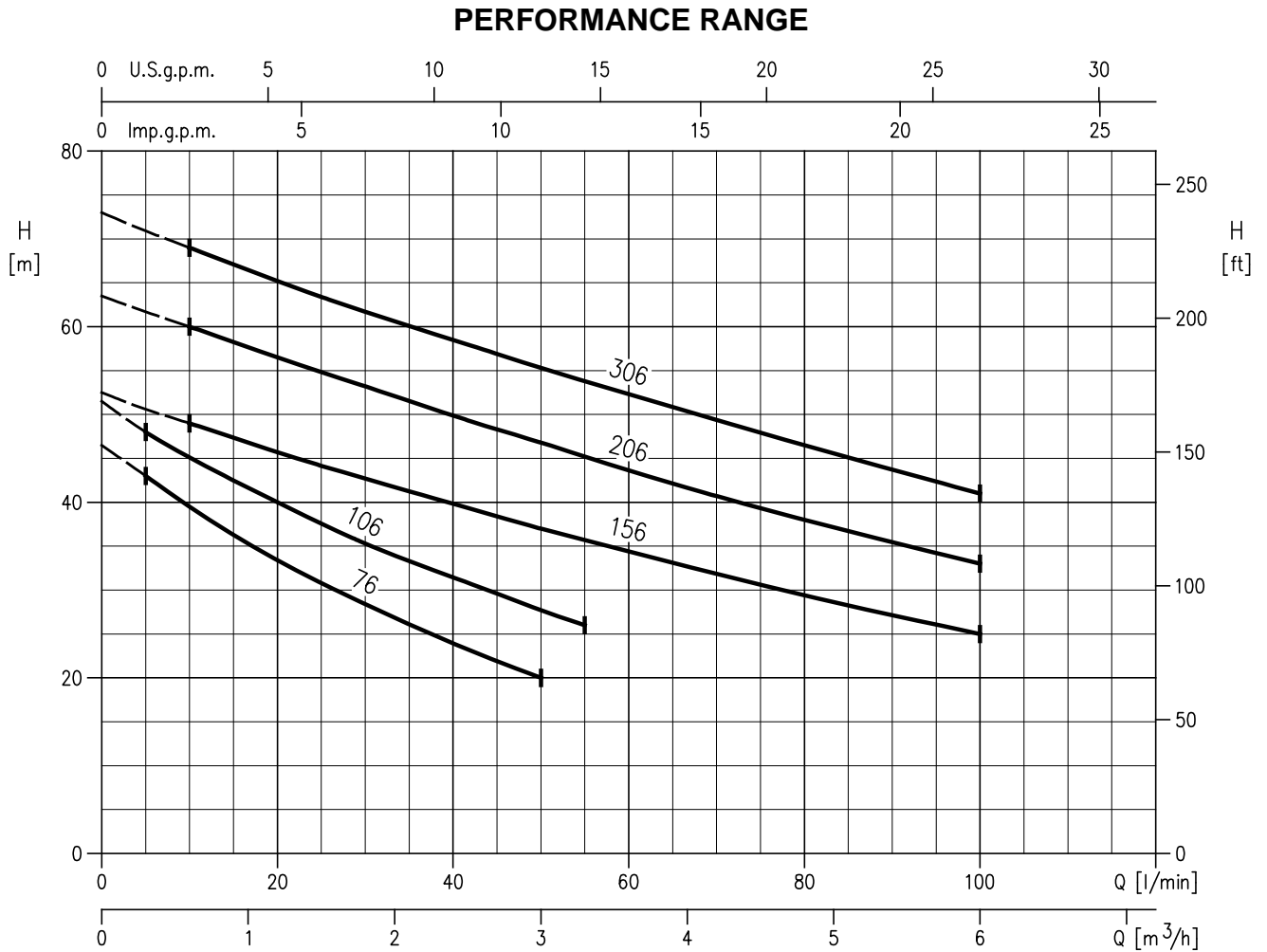

SELECTION CHART

Pump type		Power		Q =Capacity										
				l/min	0	5	10	20	30	45	50	55	80	100
Single phase	Three phase	[kW]	[HP]	m³/h	0	0.3	0.6	1.2	1.8	2.7	3.0	3.3	4.8	6.0
				H=Total head [m]										
AGA 076 M	AGA 076 T	0.55	0.75	46.5	43	39.5	33.4	28.4	21.9	20	-	-	-	-
AGA 106 M	AGA 106 T	0.75	1	51.5	48	45.1	40	35.3	29.6	27.7	26	-	-	-
-	AGA 156 T	1.1	1.5	52.5	-	49	45.7	42.7	38.4	37	35.7	29.4	25	-
AGA 206 M	AGA 206 T	1.5	2	63.5	-	60	56.5	53.2	48.3	46.8	45.2	38	33	-
-	AGA 306 T	2.2	3	73	-	69	65.2	61.7	56.9	55.3	53.8	46.5	41	-

TYPE KEY

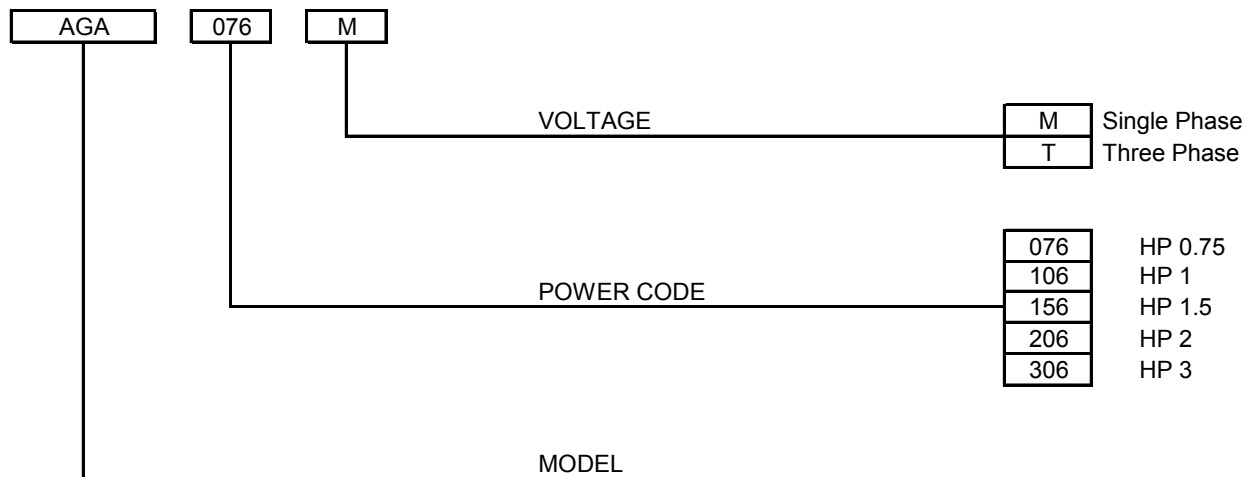

CURVES SPECIFICATIONS

The specifications below qualify the curves shown on the following pages.

Tolerances according to ISO 9906:2012 - Grade 3B

The curves refer to effective speed of asynchronous motors at 60 Hz

Measurements were carried out with clean water at 20°C of temperature and with a kinematic viscosity of $\nu = 1 \text{ mm}^2/\text{s}$ (1 cSt)

The continuous curves indicate the recommended working range. The dotted curve is only a guide.

In order to avoid the risk of over-heating, the pumps should not be used at a flow rate below 10% of best efficiency point.

Symbols explanation:

- Q = volume flow rate
- H = total head

AGA 076- Impeller diameter = 110 mm
 AGA 106- Impeller diameter = 116 mm

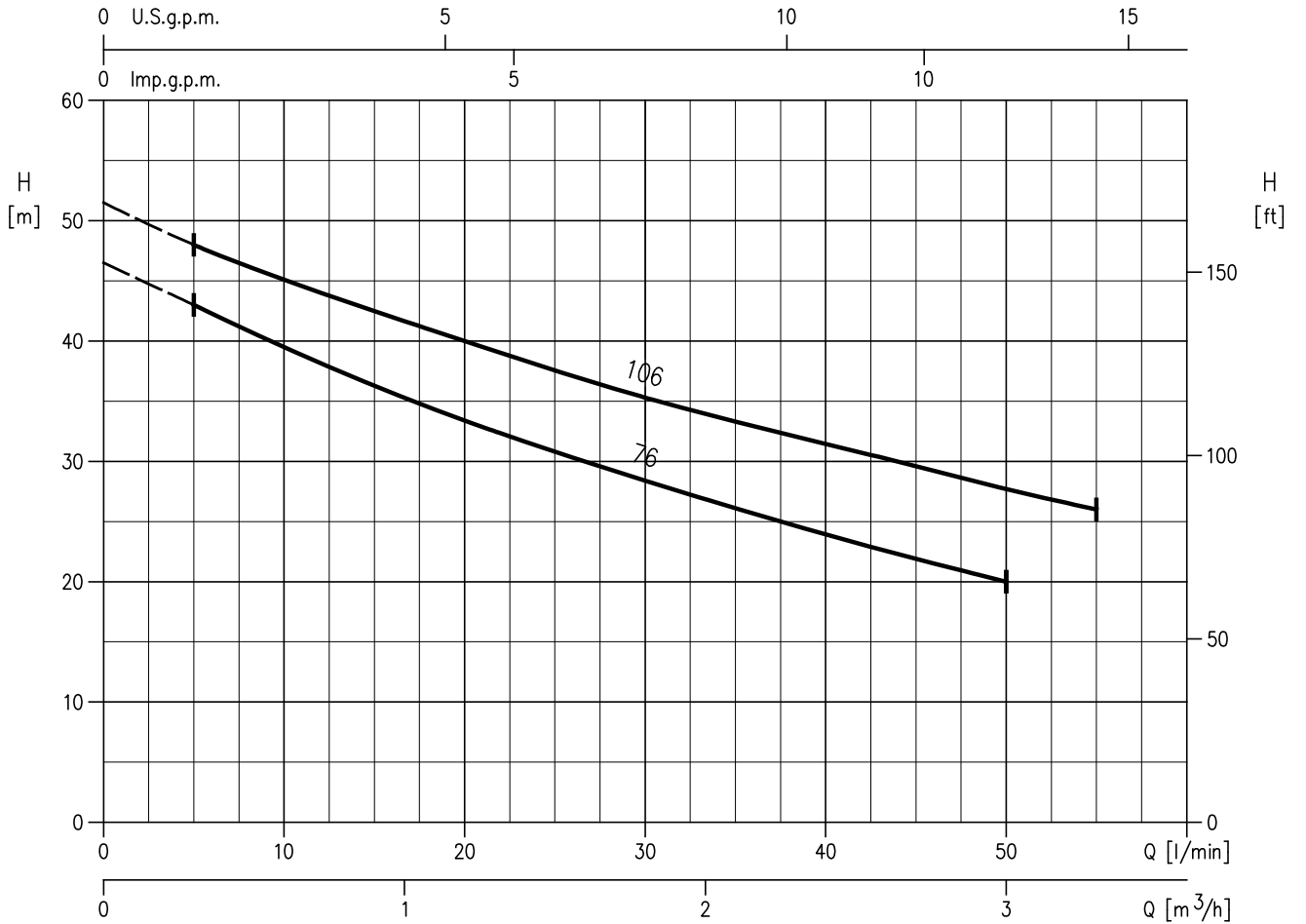

Rotation speed $\approx 3450 \text{ min}^{-1}$
 Test standard: ISO 9906:2012 - Grade 3B

AGA 156- Impeller diameter = 122 mm
AGA 206- Impeller diameter = 135 mm
AGA 306- Impeller diameter = 144 mm

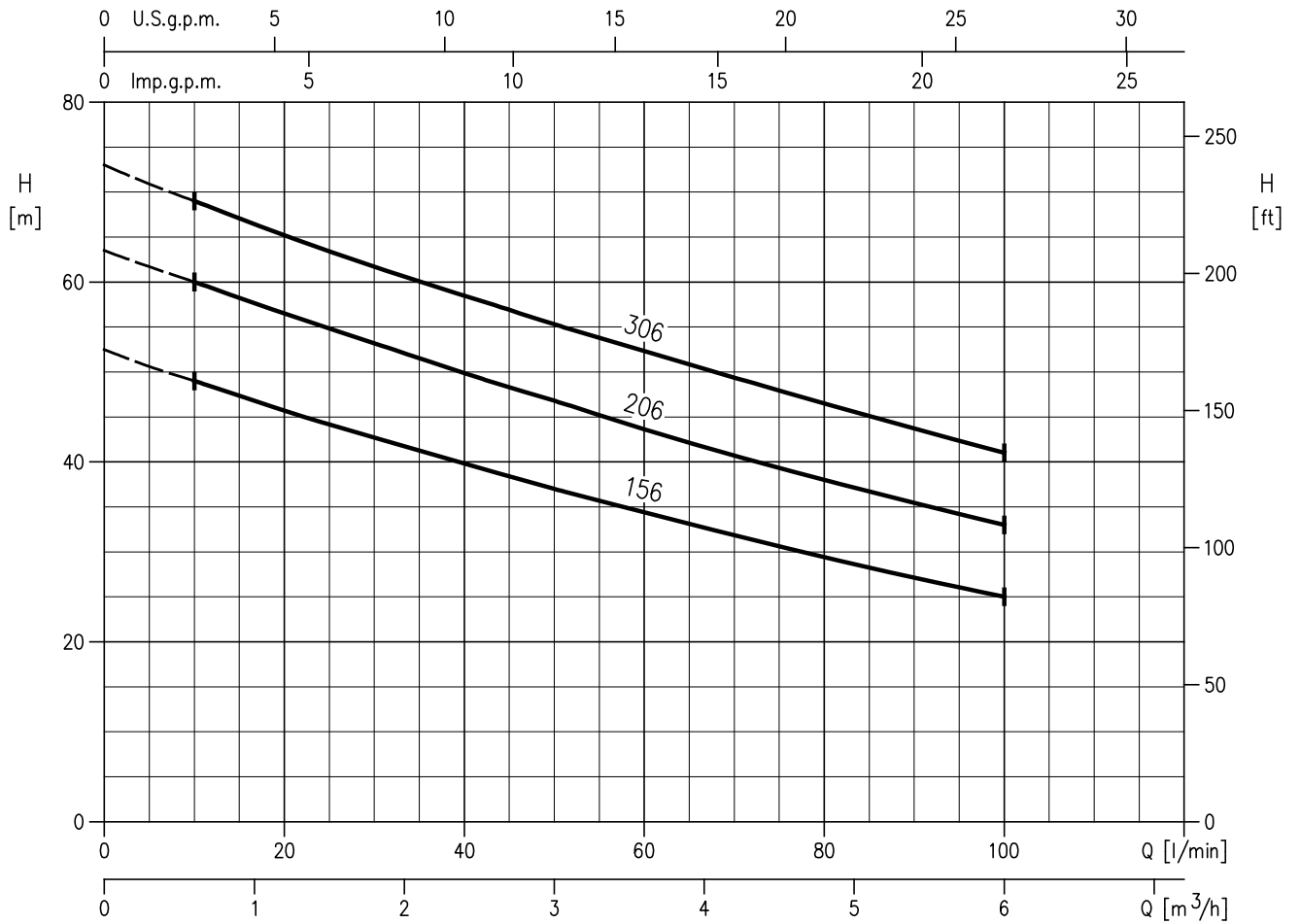

Rotation speed $\approx 3450 \text{ min}^{-1}$
 Test standard: ISO 9906:2012 - Grade 3B

SECTIONAL VIEW

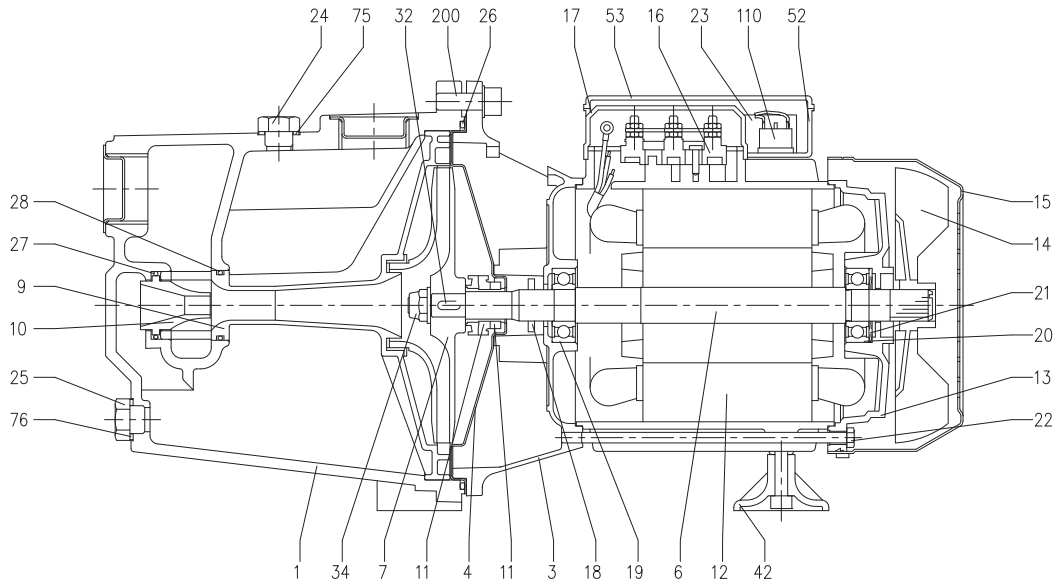

N°	PART NAME	MATERIAL	Q.TY	N°	PART NAME	MATERIAL	Q.TY
1	Casing	Cast iron	1	21	Adjusting ring	Steel C70	1
3	Motor bracket	[7]	1	22	Tie rod	Fe 42 Zincate	4
4	Casing cover [6]	AISI 304	1	23	Capacitor [2]	-	1
6	Shaft with rotor	AISI 303 (wet extension)	1	24	Priming plug	Brass	1
7	Impeller	[4]	1	25	Drain plug	Brass	1
9	Diffuser + Venturi tube	PPE+PS glass fibre reinforced	1	26	O-ring	NBR	1
10	Venturi nozzle	PPE+PS glass fibre reinforced	1	27	O-ring	NBR	1
11	Mechanical seal	Carbon/Ceramic/NBR	1	28	O-ring	NBR	1
12	Motor frame with stator	-	1	32	Key	AISI 316	1
13	Motor cover	Aluminium	1	34	Impeller nut [3]	AISI 304	1
14	Fan	PA6	1	42	Foot	PP	1
15	Fan cover	Fe P04 Zincate	1	52	Capacitor box [2]	ABS class V-0	1
16	Terminal board	-	1	53	Capacitor box cover [2] [8]	ABS class V-0	1
17	Terminal box cover [1]	Aluminium	1	75	Washer	Aluminium	1
18	Splash ring	NBR	1	76	Washer	Aluminium	1
19	Pump side ball bearing	-	1	110	Motor protector [5]	-	1
20	Fan side ball bearing	-	1	200	Screw	Zn Steel Cl. 8.8 ISO 898-1	4

[1] Only for three phase

[2] Only for single phase

[3] Only for Brass impeller version1

[4] Material : PPE+PS glass fibre reinforced for type : AGA 076 - AGA 106
Brass for type : AGA 156 - AGA 206 - AGA 306

[5] Only for version single phase AGA 206

[6] Only for version AGA 076 - AGA 106

[7] Material : Cast iron for version AGA 156 - AGA 206 - AGA 306
Aluminium for version AGA 076 - AGA 106

[8] With gasket in NBR only for version single phase AGA 106

MECHANICAL SEAL

UP TO 0.75 kW

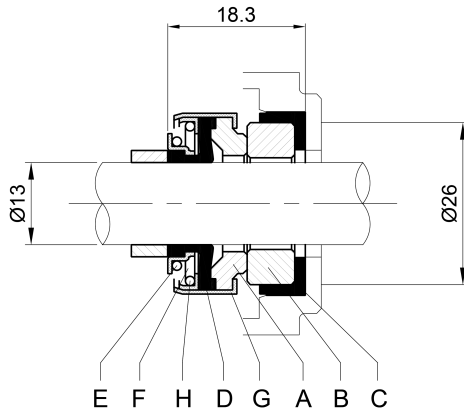

REF	PART NAME	MATERIAL
A	Rotary seal ring	Carbon graphite
B	Stationary seal ring	Ceramic
C	Gasket	NBR
D	Bellows	NBR
E	O-Ring	AISI 304
F	Self-driving spring	AISI 304
G	Frame	AISI 304
H	Retainer ring	AISI 304

1.1 kW AND ABOVE

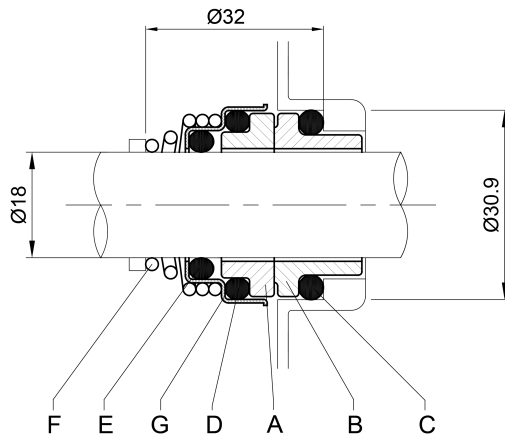

REF	PART NAME	MATERIAL
A	Rotary seal ring	Ceramic
B	Stationary seal ring	Carbon graphite
C	O-Ring	NBR
D	O-Ring	NBR
E	O-Ring	NBR
F	Self-driving spring	AISI 316
G	Frame	AISI 304

BEARINGS

Type pumps		Ball Bearing			
Single Phase	Three Phase	Pump side	(*) Pump side	Fan side	(*) Fan side
AGA 076 M	AGA 076 T	6202 2RSH	-	6202 2RSH	-
AGA 106 M	AGA 106 T	6202 2RSH	6202-ZZC3	6202 2RSH	6202-ZZC3
-	AGA 156 T	6204 2RSH	6204-ZZC3	6203 2RSH	6203-ZZC3
AGA 206 M	AGA 206 T	6204 2RSH	6204-ZZC3	6203 2RSH	6203-ZZC3
-	AGA 306 T	6204 2RSH	6204-ZZC3	6203 2RSH	6203-ZZC3

(*) Only for IE3 Motors

PUMP

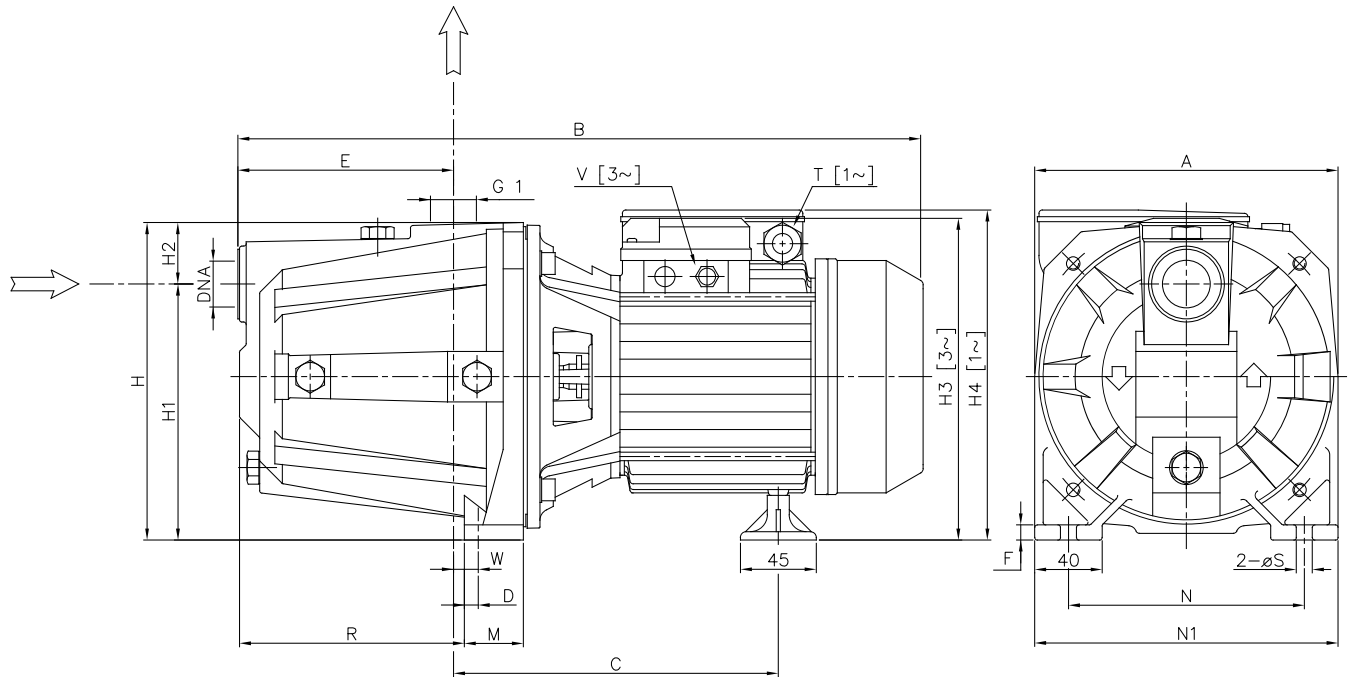

Pump type	Dimensions [mm]																			Weight [kgf]				
	A	B (*)	C	D	E	F	H	H1	H2	[3~] H3	[1~] H4	M	N	N1	R	T [1~]	V [3~] (*)	W	S	DNA		(*)		
AGA 076 M	180	405	-	195	10.3	127	9	185	152	33	-	199	40	140	180	128.5	PG11	-	-	11.8	9.5	G 1	13	-
AGA 076 T	180	405	-	195	10.3	127	9	185	152	33	197.5	-	40	140	180	128.5	-	PG11	-	11.8	9.5	G 1	13	-
AGA 106 M	180	405	-	195	10.3	127	9	185	152	33	-	199	40	140	180	128.5	PG11	-	-	11.8	9.5	G 1	14	-
AGA 106 T	180	405	405	195	10.3	127	9	185	152	33	197.5	-	40	140	180	128.5	-	PG11	M16x1.5	11.8	9.5	G 1	14	14
AGA 156 T	220	495	520	244	10	157	10	223	170	53	229	-	48	175	220	167.5	-	PG11	M20x1.5	15.5	9	G 1 1/2	26	26
AGA 206 M	220	521	-	244	10	157	10	223	170	53	-	247	48	175	220	167.5	PG13.5	-	-	15.5	9	G 1 1/2	27	-
AGA 206 T	220	495	520	244	10	157	10	223	170	53	229	-	48	175	220	167.5	-	PG11	M20x1.5	15.5	9	G 1 1/2	28	29
AGA 306 T	220	508	521	244	10	157	10	223	170	53	229	-	48	175	220	167.5	-	PG11	M20x1.5	15.5	9	G 1 1/2	28	29

[1~] Single phase
 [3~] Three phase
 (*) Only for IE3 Motors

PACKING

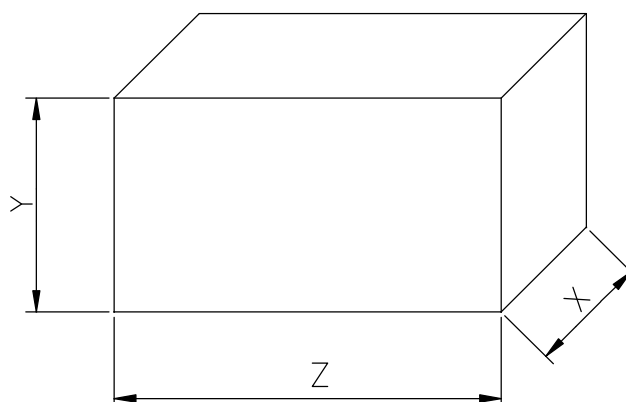

Type pumps		Packing [mm]			Weight [kgf]		
Single Phase	Three Phase	X	Y	Z	[1~]	[3~]	(*)
AGA 076 M	AGA 076 T	205	250	445	13	13	-
AGA 106 M	AGA 106 T	205	250	445	15	15	15
-	AGA 156 T	232	275	547	26	26	27
AGA 206 M	AGA 206 T	232	275	547	28	28	29
-	AGA 306 T	232	275	547	-	29	29

[1~] Single phase
 [3~] Three phase
 (*) Only for IE3 Motors

MOTOR DATA

Pump type		Power		Capacitor				Efficiency (% load)			Efficiency (% load)			Input		Full load current					Locked rotor current							
Single Phase	Three Phase	[kW]	[HP]	220-230 V				Three phase (380 V)			Three phase (460* V)			Single Phase	Three Phase	[A]					[A]							
				110-115 V [μF]	110-115 V [V]	220-230 V [μF]	220-230 V [V]	50%	75%	100%	50%	75%	100%			Single Phase	Three Phase				Single Phase			Three Phase				
AGA 076 M	AGA 076 T	0.55	0.75	60	250	14	450	-	-	-	-	-	-	0.94	0.9	9.5	4.3	2.8	1.6	-	-	-	-	-	-	-	-	-
AGA 106 M	AGA 106 T	0.75	1.0	60	250	20	450	80.7	81.9	81.3	78.4	81.6	83.1	1.1	0.90	11.4	5.5	2.8	1.6	1.5	52	26	16.9	9.7	11.8			
AGA 156 M	AGA 156 T	1.1	1.5	100	250	35	450	84.2	84.7	84.5	83.2	84.7	85.7	1.65	1.75	17.1	8.0	5.3	3.1	2.9	-	55	40.2	23.2	28.1			
AGA 206 M	AGA 206 T	1.5	2.0	-	-	40	450	84.2	84.7	84.5	83.2	84.7	85.7	2.10	1.75	-	11.0	5.3	3.1	2.9	-	69	40.2	23.2	28.1			
-	AGA 306 T	2.2	3.0	-	-	-	-	86.5	86.8	86.2	86.9	87.8	87.4	-	2.48	-	-	7.5	4.3	4.1	-	-	55.7	32.2	38.9			

(*) IE3 Motors